

# FLEXI DENIM 2C

## The most flexible laser system of the Flexi Denim line.

- **Flexi Denim 2C** has been specifically designed for the laser marking, printing and finishing of garments like blue jeans, trousers, T-shirts etc. and is able to substitute the traditional finishing operations such as discoloration, abrasion, decoration.
- **Flexi Denim 2C** is a complete modular and flexible system, suitable for all modern production and workflow needs.
- The system is equipped with two conveyors that allow both a continuous workflow (used separately) and the finishing of extra-large size garments (working jointly).
- **Flexi Denim 2C** has a special laser preview, assisting the operator in production, facilitating even the most complicated garment positioning sequences.
- EnGenius software helps to create an extremely realistic 3D modeling preview of the final garment, by visualizing and enabling the design of all desired laser finishing effects (used looks, broken effects, perforations, designs and writings).
- Thanks to the special SEI Vero function it is possible to reach a true natural look of the denim garment with full environmental care.



*Custom laser preview*



*Two conveyors system*





# FLEXI DENIM 2C

## Main technical features:

Version	V 150	V 300	V 500
Laser technology	Sealed CO <sub>2</sub> laser source excited by RF discharge		
Laser wavelength (µm)	10,6/0,52		
Scan head technology	4 optical axis (3 galvo + 1 step motors)		
Working area-double conveyor (mm)	1300x1450 (650x1450-single conveyor)		
Control unit	PC Windows™ with SW Icaro DENIM pre-installed		
Laser power control	Denim mode, proprietary algorithm		
Norm compliance	2014/35/UE Low voltage directive		
	2006/42/CE Machinery directive		
	2014/30/UE Electromagnetic Compatibility Directive		
	IEC EN 60825-1 Laser		



## Main benefits:

- Safety and modularity for an extremely simple installation;
- State-of-the art performances for maximum energy efficiency and simplified care;
- Top productivity: up to 4 times more than traditional laser systems;
- Finishing process dramatically reducing total water consumption;
- Remote control and diagnostic module included;
- Hi-resolution and natural effects with grey scale;
- User-friendly software developed by SEI Laser: all steps intuitive and very simple;
- Double conveyor for optimization of production lead times;
- Smart manufacturing ready (Industry 4.0).

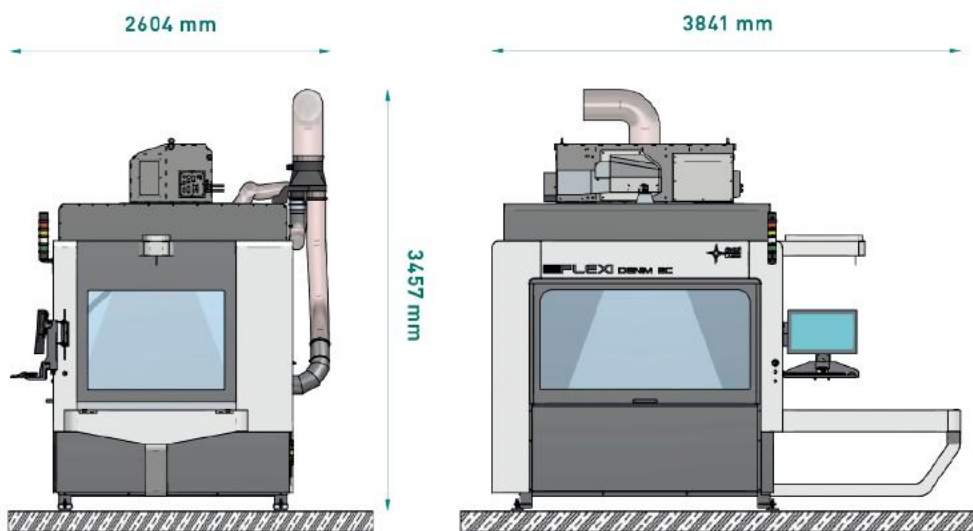

Max. weight: 2000 Kg

### 3D EnGenius

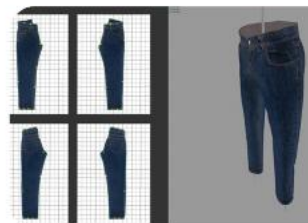

### SEI Vero



## SEI LASER Systems (Shaoxing) Co.Ltd

No.128,ZheDuan Road,Pukou Development Zone,Shengzhou City, Zhejiang,China

T.+86 575 83933766 - www.seilaserasia.com